

TB 9-4931-541-50

DEPARTMENT OF THE ARMY TECHNICAL BULLETIN

CALIBRATION PROCEDURE FOR DIAL INDICATOR CALIBRATOR ITALL MODEL 700

Headquarters, Department of the Army, Washington, DC

2 December 2002

Approved for public release; distribution is unlimited

REPORTING OF ERRORS AND RECOMMENDING IMPROVEMENTS

You can improve this manual. If you find any mistakes or if you know of a way to improve these procedures, please let us know. Mail your letter, DA Form 2028 (Recommended Changes to Publications and Blank Forms) directly to Commander, U.S. Army Aviation and Missile Command, ATTN: AMSAM-MMC-MA-NP, Redstone Arsenal, AL 35898-5000. A reply will be furnished to you. You may also provide DA Form 2028 information to AMCOM via e-mail, fax, or the World Wide Web. Our FAX number is: DSN 788-6546 or Commercial 256-842-6546. Our e-mail address is: 2028@redstone.army.mil. Instructions for sending an electronic 2028 may be found at the back of this manual immediately preceding the hard copy 2028. For the World Wide Web, use: <https://amcom2028.redstone.army.mil>.

SECTION		Paragraph	Page
	I. IDENTIFICATION AND DESCRIPTION		
	Test instrument identification.....	1	2
	Forms, records, and reports.....	2	2
	Calibration description.....	3	2
	II. EQUIPMENT REQUIREMENTS		
	Equipment required.....	4	2
	Accessories required.....	5	2
	III. CALIBRATION PROCESS		
	Preliminary instructions.....	6	3
	Equipment setup.....	7	3
	Accuracy.....	8	7
	Final procedure.....	9	8

**SECTION I
IDENTIFICATION AND DESCRIPTION**

1. Test Instrument Identification. This bulletin provides instructions for the calibration of Dial Indicator Calibrator, ITALL Model 700. The manufacturer’s instruction manual was used as the prime data source in compiling these instructions. The dial indicators will be referred to as the TI test instrument throughout this bulletin.

a. Model Variations. None.

b. Time and Technique. The time required for this calibration is approximately 1 hour for each TI using the physical technique.

2. Forms, Records, and Reports. Forms, records and reports required for calibration personnel at all levels are prescribed by TB 750-25.

3. Calibration Description. TI parameters and performance specifications that pertain to this calibration are listed in table 1.

Table 1. Calibration Description

Test instrument parameters	Performance specifications
Range	0.0 to 1 in.
Accuracy	±0.000021 in.

**SECTION II
EQUIPMENT REQUIREMENT**

4. Equipment Required. Table 2 identifies the specific equipment to be used in this calibration procedure. This equipment is issued with Secondary Reference Calibration Standard Set, NSN 4931-00-621-7878. Alternate items may be used by the calibrating activity. The items selected must be verified to perform satisfactorily prior to use and must bear evidence of current calibration. The equipment must meet or exceed the minimum use specifications listed in table 2. The accuracies listed in table 2 provide a four-to-one ratio between the standard and TI.

5. Accessories Required. The accessories used in this calibration procedure are furnished with length gauge (table 2). The following peculiar accessory is also required for this calibration: Gimbaled Fixture, Model 638.

Table 2. Minimum Specifications of Equipment Required.

Common Name	Minimum Use Specifications	Manufacturer, Model and Part Number
LENGTH GAUGE	Range: 0.0 to 1 in. Accuracy: ±0.000005 in.	CT 2502 (CT 2502)

**SECTION III
CALIBRATION PROCESS**

6. Preliminary Instructions

a. The instructions outlined in paragraphs **6** and **7** are preparatory to the calibration process. Personnel should become familiar with the entire bulletin before beginning the calibration.

b. Items of equipment used in this procedure are referenced within the text by common name. For identification of equipment see table 2.

c. Unless otherwise specified, verify the result of each test and, whenever the test requirement is not met, take corrective action before continuing with the calibration. Adjustments required to calibrate the TI are included in this procedure. Additional maintenance information is contained in the

d. Unless otherwise specified, all controls and control settings refer to the TI.

7. Equipment Setup

WARNING

HIGH VOLTAGE is used or exposed during the performance of this calibration. DEATH ON CONTACT may result if personnel fail to observe safety precautions.

a. Allow length gauge and TI to stabilize to room temperature.

b. Connect indicators as shown in figure 1. Fasten length gauge to TI, as shown in figure 1, using gimbaled fixture supplied with length gauge.

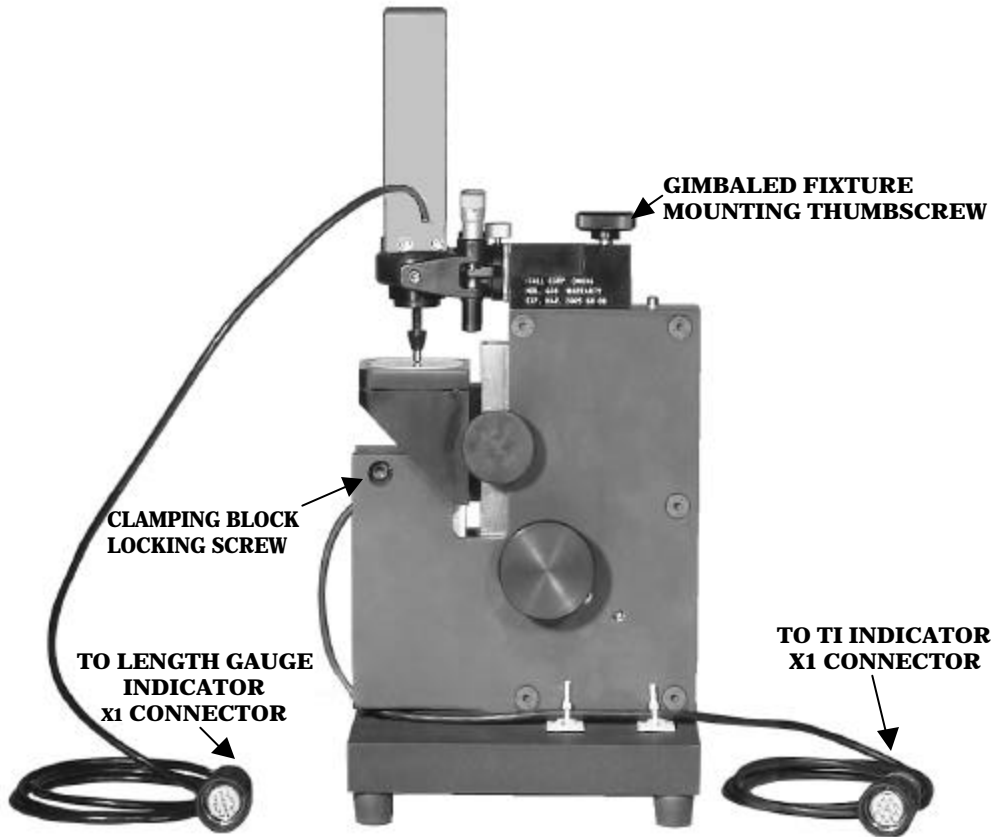

Figure 1. Equipment Setup.

c. Connect both indicators to 115 V ac power source. Turn power switches to on and allow length gauge and TI to warm up for 15 minutes.

d. Both indicators will indicate **ENT ...CL**, press **CL**. The last three digits on the readout may continually fluctuate depending on the environmental conditions and the warm-up time allowed. The **ACTL** and **INCH** LEDs should be activated.

NOTE

If **ACTL** is not activated on the display, continue pressing **MOD** until **ACTL** flashes on display, then press **ENT** and **CL**. If any other indications are incorrect, see PG 7 paragraph 4.6.4 of the Dial Indicator Calibrator Itall Model 700 manual for proper programming.

NOTE

Ensure that TI contact surface remains in contact with the length gauge contact point and the TI transducer contact point throughout the calibration procedure. This will allow use of the best range of the transducer and length gauge. If it is necessary to adjust the position of the TI transducer, see note below.

CAUTION

Do not loosen any screws on the left side of the clamping block. Loosening these screws will misalign the transducer and cause unwanted errors. Be careful not to pinch the cable.

NOTE

Adjustment procedure follows: Place the TI (without indicator) in a horizontal (back down) position. Loosen the clamping-block locking screw (fig. 1) 1/4 of a turn counterclockwise, using a 3/16 inch Allen wrench. Position transducer as necessary; turn the clamping-block locking screw (figure 1) 1/4 of a turn clockwise, using a 3/16 inch Allen wrench until it is securely clamped and there is no binding of the transducer spindle. It is important that the TI transducer spindle move freely and the transducer not slip.

e. Loosen mounting ring thumbscrew (fig. 2). Adjust mounting ring until the length gauge shaft is in direct vertical alignment with the TI shaft. Tighten mounting ring thumbscrew.

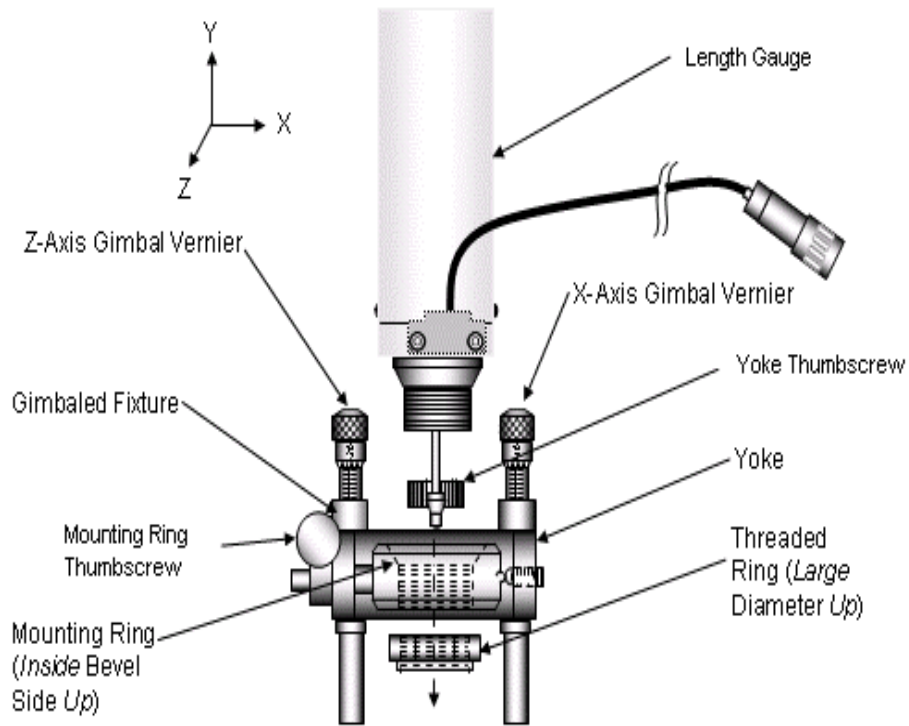

Figure 2. Gimballed fixture and length gauge.

f. Loosen yoke thumbscrew and adjust YOKE (fig. 2) so that the length gauge shaft is in direct vertical alignment with the TI shaft. Tighten yoke thumbscrew.

g. Adjust the TI course adjustment knob so that the TI contact surface is fully raised. Loosen gimballed fixture mounting thumbscrew (fig. 1). Adjust gimballed fixture so that the length gauge contact point is aligned with the TI contact point (fig. 3). Tighten gimballed fixture mounting thumbscrew

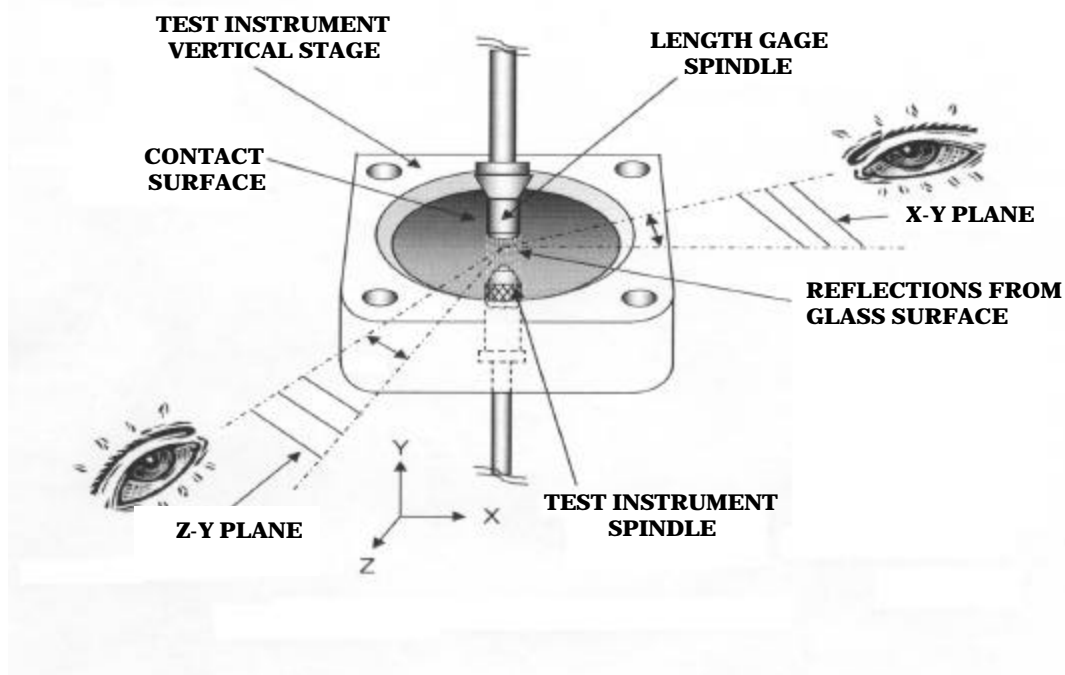

Figure 3. Length gauge spindle alignment.

h. Adjust X-AXIS GIMBLE VERNIER (fig 2) to highest value reading on length gauge indicator. Repeat for Z-AXIS GIMBLE VERNIER (fig 2). Repeat as necessary for best possible setting.

NOTE

When making this adjustment, it is important that minimal downward force is applied with the hand to the vernier. Downward force may cause problems during this adjustment. To avoid this problem, place elbow on the solid table surface near the TI. Using a delicate touch with thumb and forefinger, grasp and rotate the vernier a small amount at a time.

8. Accuracy

a. Performance Check

(1) Press the **0** and **ENT** keys on the length gauge indicator and the TI indicator to zero the indicators.

CAUTION

Any movement or vibration of the TI stand, transducer, length gauge or gimbale fixture may cause erroneous readings.

TB 9-4931-541-50

(2) Adjust TI course adjustment knob to obtain 8 or more points across the range of the TI. Difference in length gauge indicator absolute reading and TI indicator absolute reading should be within .000021 inches.

(3) Adjust TI course adjustment knob so that the length gauge contact point is fully lowered while maintaining contact with the TI contact surface. Press the **0** and **ENT** keys on the length gauge indicator and the TI indicator to zero the indicators. Repeat (2) above for the upward direction.

b. Adjustments. No adjustment can be made.

9. Final Procedure

a. Deenergize and disconnect all equipment.

b. Annotate and affix DA label/form in accordance with TB 750-25.

THESE ARE THE INSTRUCTIONS FOR SENDING AN ELECTRONIC 2028

The following format must be used if submitting an electronic 2028. The subject line must be exactly the same and all fields must be included; however, only the following fields are mandatory: 1, 3, 4, 5, 6, 7, 8, 9, 10, 13, 15, 16, 17, and 27.

From: "Whomever" whomever@avma27.army.mil

To: 2028@redstone.army.mil

Subject: DA Form 2028

1. **From:** Joe Smith
2. **Unit:** Home
3. **Address:** 4300 Park
4. **City:** Hometown
5. **St:** MO
6. **Zip:** 77777
7. **Date Sent:** 19-Oct-93
8. **Pub No:** TB 9-6625-xxxx-35
9. **Pub Title:** Calibration Procedure for ...
10. **Publication Date:**
11. **Change Number:**
12. **Submitted Rank:** MSG
13. **Submitter Fname:** Joe
14. **Submitter Mname:** T
15. **Submitter Lname:** Smith
16. **Submitter Phone:** (123) 123-1234
17. **Problem:** 1
18. **Page:** 2
19. **Paragraph:** 3
20. **Line:** 4
21. **NSN:** 5
22. **Reference:** 6
23. **Figure :** 7
24. **Table:** 8
25. **Item:** 9
26. **Total:** 123
27. **Text:**

This is the text for the problem below line 27.

TB 9-4931-541-50

By Order of the Secretary of the Army:

ERIC K. SHINSEKI
General, United States Army
Chief of Staff

OFFICIAL:

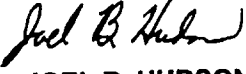
JOEL B. HUDSON
Administrative Assistant to the
Secretary of the Army

0227705

Distribution:

To be distributed in accordance with initial distribution number (IDN) 344754 requirements for TB 9-4931-541-50.

PIN: 080357-000